



SF410M (BF)

FULL CELL LINE



Peimar monocrystalline solar panels, produced using a combination of innovative production processes and advanced engineering techniques, provide customers with maximum output and super high performance.

This allows fewer panels to be used to generate more energy, ideal if space is restricted or environmental conditions are challenging. Modern design, using matching black cells and frames and a very long lifespan ensure this monocrystalline are a great option.

30 YEAR LINEAR POWER WARRANTY
30 YEAR PRODUCT WARRANTY



PERC TECHNOLOGY



MODULE FIRE PERFORMANCE: **CLASS 1**



ANTI-REFLECTIVE GLASS



QBE INSURANCE
Product Liability Insurance QBE

Cells



66 CELLS
MONO gBB M6 | PERC

166 x 166 mm / 6.54 x 6.54"

Frame



COMPACT AND STURDY | 40mm

ANCHORABLE ALSO ON
THE SHORT SIDE ⁽³⁾

Electrical Characteristics (STC) ⁽¹⁾

SF410M (BF)

Nominal Output (Pmax) ⁽²⁾	410 W
Sorting Tolerance	0/+5 W
Voltage at Pmax (Vmp)	38.4 V
Current at Pmax (Imp)	10.68 A
Open Circuit Voltage (Voc) ⁽²⁾	46.08 V
Short Circuit Current (Isc) ⁽²⁾	11.31 A
Maximum System Voltage	1500 V
Maximum Series Fuse Rating	20 A
Module Efficiency	20.59 %
Protection class against electric shock	Class II

Mechanical Characteristics

Solar Cells	66 (6 x 11) M6 monocrystalline PERC
Solar Cells Size	166 x 166 mm / 6.54 x 6.54"
Front Cover	3.2 mm / 0.13" thick, low iron tempered glass
Back Cover	TPT (Tedlar-PET-Tedlar)
Encapsulant	EVA (Ethylene vinyl acetate)
Frame	Anodized aluminium alloy, double wall
Frame finishing	Black
Backsheet finishing	White
Diodes	3 Bypass diodes serviceable
Junction Box	IP67 rated
Connector	MC4 or compatible connector
Cables Length	1100 mm / 43.31"
Cables Section	4.0 mm ² / 0.006 in ²
Dimensions	1900 x 1048 x 40 mm / 74.80 x 41.25 x 1.57"
Weight	22 kg / 48.5 lbs
Max Load (Test Load) - SF	5400 Pa - 15 ⁽³⁾

Temperature Characteristics

NMOT ⁽³⁾	45±2 °C
Temperature Coefficient of Pmax	-0.37 %/°C
Temperature Coefficient of Voc	-0.28 %/°C
Temperature Coefficient of Isc	0.042 %/°C
Operating Temperature	-40 °C - +85°C

Packaging ⁽⁴⁾

Pallet dimensions	1950 x 1200 x 1210 mm / 76.77 x 47.24 x 47.64"
Pieces per pallet	27
Weight	610 Kg / 1344 lbs

Certifications

Fire Resistance Rating	Class of reaction to fire 1 (UNI g177)
------------------------	--

Dimensions

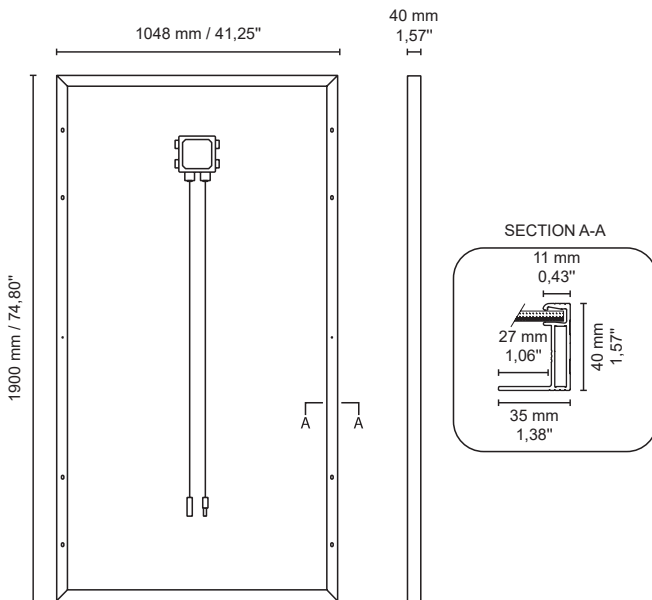

Current/Voltage Characteristics

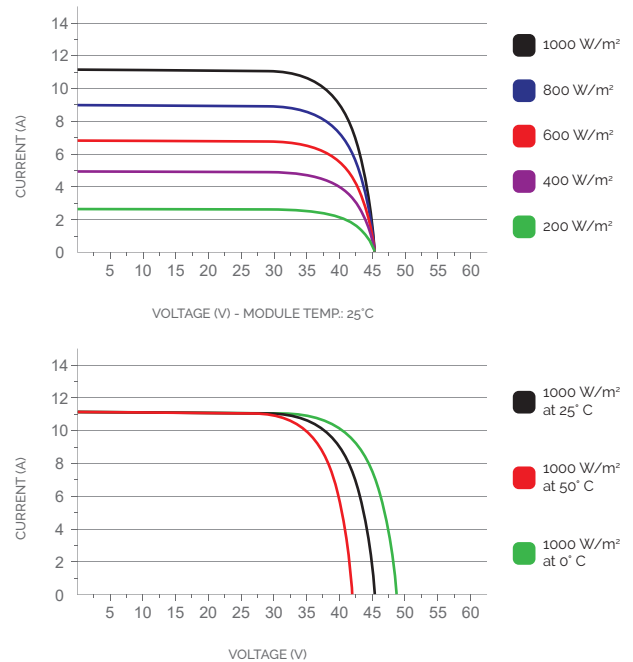

1. STC: (Standard Test Condition) Irradiance 1000W/m², Module Temperature 25°C, Air Mass 1.5

2. Pmax, Voc, Isc measurement tolerance: ±3%

3. NMOT: Nominal Module Operating Temperature. Irradiance 800W/m², Air 20°C, Wind speed 1m/s

4. Pallets can be stacked up to two

5. Consult the installation manual for the relative mounting configurations